

# Controller Designer Software Specifications

51-52-03-43, September 2018



## Description

Controller Designer software for the ControlEdge HC900 Controller is an easy-to-use Windows-based application that is operable over Ethernet, a serial port or modem connection to simplify controller configuration. Designer software supported in English and Mandarin language. When used with the C70 series CPUs with dual Ethernet capability, Controller Designer software supports verification of both communication ports and may be used with either port.

It provides advanced monitoring functions for debug, allows RUN/PGM-mode configuration changes, uploads the complete, annotated graphic controller control strategy, plus supplies an array of reports for enhanced documentation.

Figure 1 - Controller Designer Software

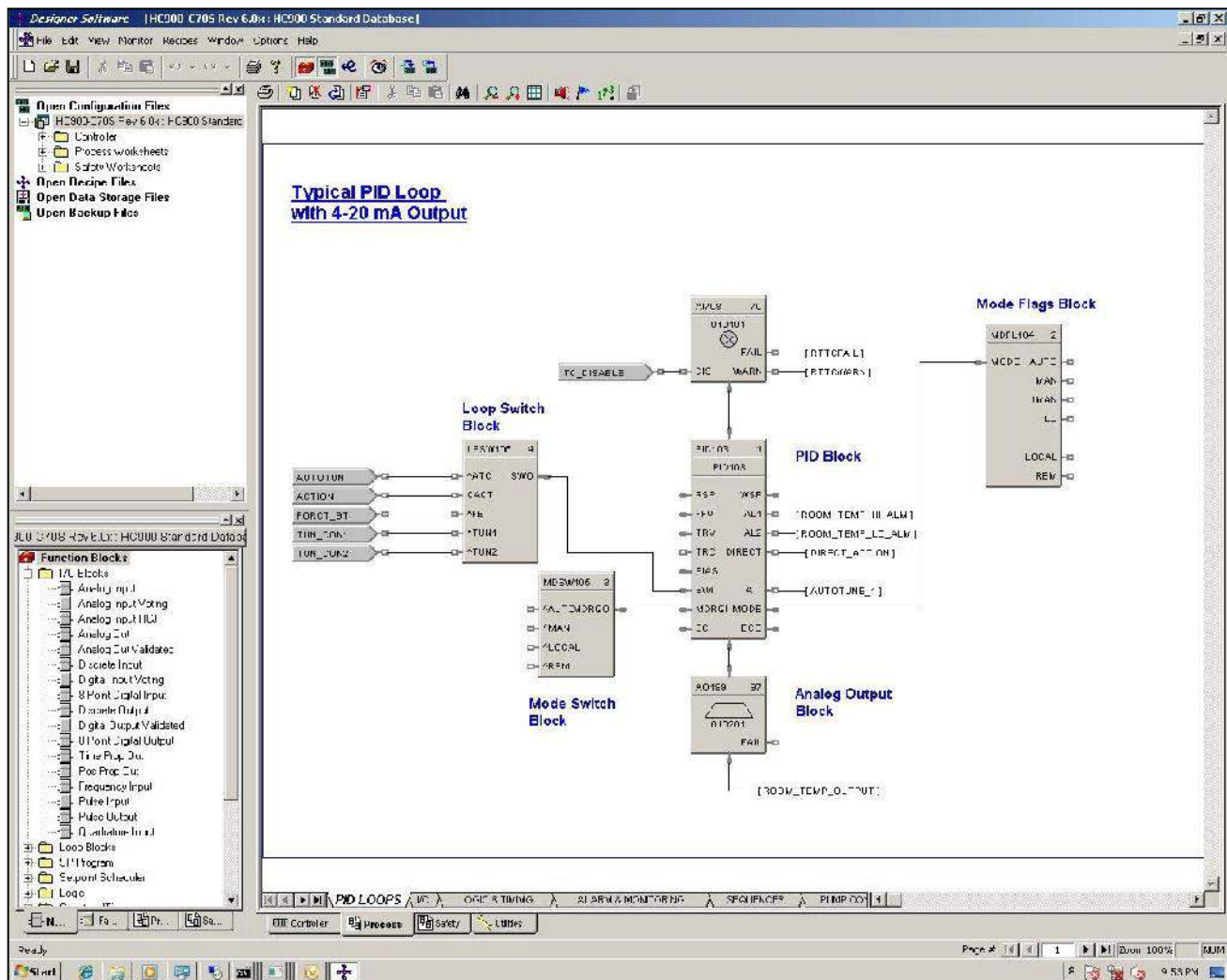

## Features

- Graphic drag and drop, soft-wire configuration
- Supports configuration edit downloads in RUN mode
- Version Control System
- User Library Creation
- Configures:
  - Controller
  - Peer-to-peer data exchange (Peer and safety peer communication)
  - Recipes, SP profiles,
  - SP Schedules, Sequences
  - Alarms, events, e-mail alarms/events
  - Modbus Serial and Modbus TCP Master communications
- Graphic function block configuration and annotations
- Allows graphic configuration partitioning for Process and Safety
- Extensive on-line monitoring features including:
  - User defined and pre-defined watch windows
  - Power flow indication
  - Function block pin values
  - Multiple function block access
  - Signal trace-back to source
- 5 Zoom levels for detail viewing
- On-line diagnostic windows for analyzing controller, I/O, network host and controller peer connections
- Windows™ 7 (32 and 64 bit OS)
- Windows™ 8.1 (32 and 64 bit OS)
- Windows 10 (32 and 64 bit OS)
- Supports Ethernet, RS 485 direct connection to access controller

The ControlEdge HC900 Controller Designer provides separate functional tabbed worksheets for:

- Controller hardware setup
- 559 Operator interface setup
- Function block configuration for Process
- Function block configuration for Safety
- Utilities, communication ports setup and other diagnostic support.
- Custom Modbus Map

The user-friendly graphic function block development environment allows partitioning of the control strategy into

up to 160 (40 for version below 6.6) “worksheets” of 20 pages each.

This allows the configuration to be organized according to Process and Safety function, providing faster configuration access, and improved documentation. In addition, OEMs may apply additional security to specific worksheets to prohibit access to proprietary operations while allowing their customers to modify unprotected worksheets. For maximum security, the default password access feature for worksheets may be disabled.

Function Blocks are selected from a categorized list, dropped on a selected worksheet page, and soft-wired to other blocks directly or via tag references. Index numbers allow users to read or write data within the block when the data type is not brought to an output pin of the object. Editing tools such as box copy and paste speed development. You may also copy and paste portions of strategies from other configurations. The Undo feature provides a convenient method to reverse incorrect or undesired actions.

## Configuration Management

The controller configuration file may be imported directly into Station Designer software for configuring 900 Control Station operator interfaces. Maintaining controller and operator interface configuration files that match the actual configuration being executed in the controller is a simple task with Controller Designer’s configuration upload capability. When a PC with Controller Designer software is in communication with the controller, the Upload feature reads the configuration from the controller’s memory and back-builds an exact configuration file in the PC, including all text annotations used to describe functional areas. This file can then be saved to disk as a back-up and downloaded when needed to simplify maintenance.

New versions of Controller Designer software may be used to develop configurations for older controller versions. Configurations developed for early firmware versions of ControlEdge HC900 Controllers are automatically converted to be compatible with newer controller versions when saved as the desired version level. All controllers in the ControlEdge HC900 product line are supported with the same software. Configurations developed with Control Builder software version 5.0 for UMC800 Controllers may also be converted for use with ControlEdge HC900 controllers.

### Configuration Edits-RUN Mode

Configuration changes such as block additions or substitutions and soft-wiring can be transferred to the controller during the RUN/PRGM mode, avoiding initialization. All outputs and status are held during a minimal transfer time after which processing continues at the start of a scan. Changes with I/O module updates require additional time. The amount of time the outputs will be held, typically several seconds, is presented to the user at the time of download along with options to proceed.

Configuration changes downloaded to the controller while the controller is in the Program mode, or if cold start is selected while in the Run mode, all controller outputs are turned off and a re-initialization of the controller database is executed.

### Configuration File Properties

Configuration file properties are maintained during configuration development identifying the date of initial file creation and the date of the last file modification. Areas are provided to include a configuration name and the name of the author. During configuration, a Statistics summary (Figure 2) indicates the amount of controller resources used by the configuration and the amount of resources available. Security is provided via password entry to limit access to the entire configuration or to only user specified configuration worksheets.

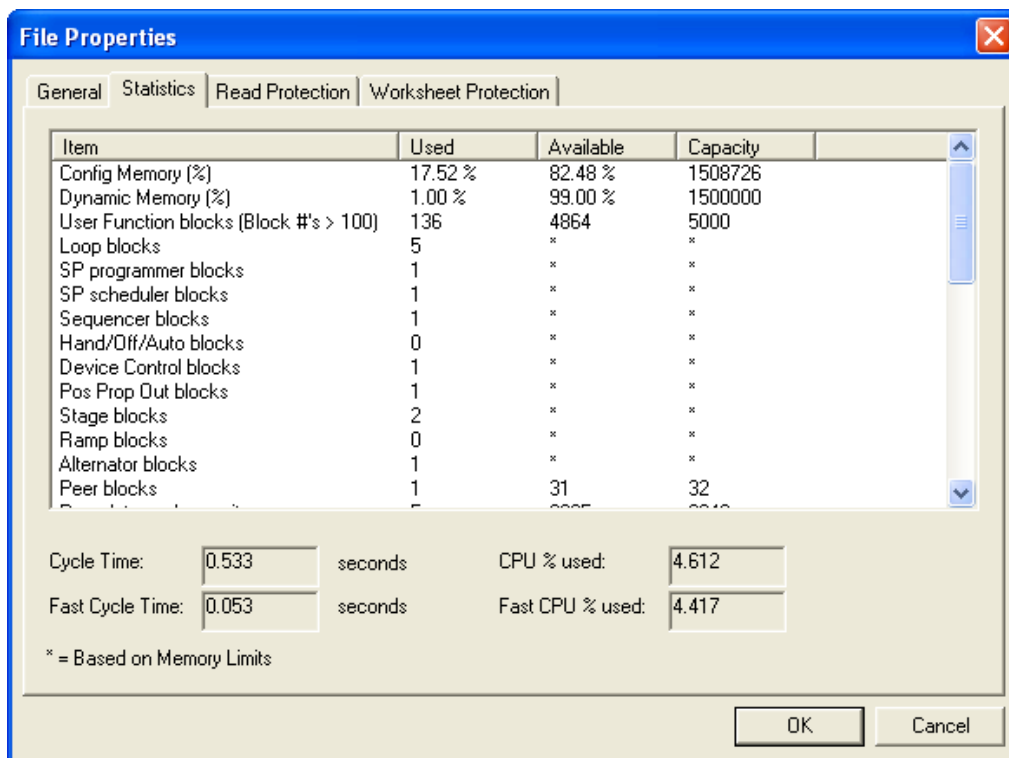

Figure 2 - File properties

## Edit mode Overview

File Browser shows all open files (configurations, recipes, data storage, and backup)

Main Menu

Main Tool Bar

Function-related Tool Bar

Double-click on block for properties

Status Bar

Functional Tabs (left to right) (see page 20 for details):

**Controller** - lists I/O used, e-mail alarms

**Display** - format select, tag assignment, F-key assignment (limited to versions prior to 6.0)

**Function Blocks** - graphic configuration (shown above)

**Modbus Map** - shows custom Modbus addresses

**Utilities** - setup for ports, data storage, time, calibration and diagnostics

Config tab lists all configured blocks, click on any block to find.

Worksheet Toolbox lists available Function Blocks and software tools, categorized by tabs Normal/Fast Scan & by block type.

#	Title	Pos	Format	Grp/Tag
1	8 Loop Faceplate (1-8)			
2	4 Loop Faceplate (1-4)			
3	3 Loop Faceplate (1-3)			
4	1 Loop Faceplate with Trend			Tag 1 - F2:ZONE1 (Fun2 Zone1)
5	1 Loop Faceplate with Trend			Tag 2 - F2:ZONE2 (Fun2 Zone2)
6	1 Loop Faceplate with Trend			Tag 3 - F2:ZONE3 (Fun2 Zone3)
7	1 Loop Numeric			Tag 4 - F2:CARB (F2%Carbon)
8	1 Loop Faceplate with Trend			Tag 8 - TYP-PID
9	3 Loop Faceplate (10-12)			
10	16 Loop Faceplate (1-16)			

## On-Line Monitoring Features

Controller Designer on-line monitoring tools allows quick analysis of configuration problems. Tools include:

1. **Multiple function block monitor access on a single display from multiple worksheets.** Most internal parameters are available for read/write plus block outputs may be forced including I/O and logic blocks. Principle blocks such as PID, Setpoint Programmer and Sequencers have dialog boxes to allow operation and test. Stored profiles or sequences may also be selected on-line.

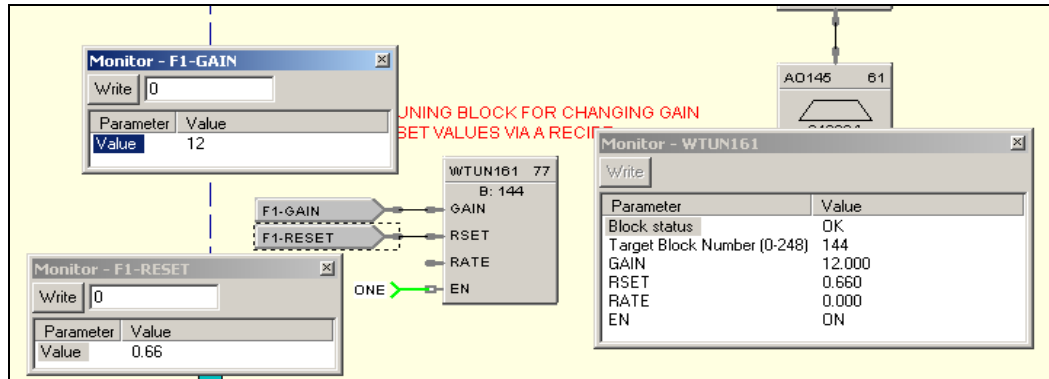

Figure 3 - Multiple function block monitoring

2. **Logic Power Flow indication.** You can choose solid green = ON/dotted red = OFF or solid red = ON/dotted green = OFF to indicate power flow.

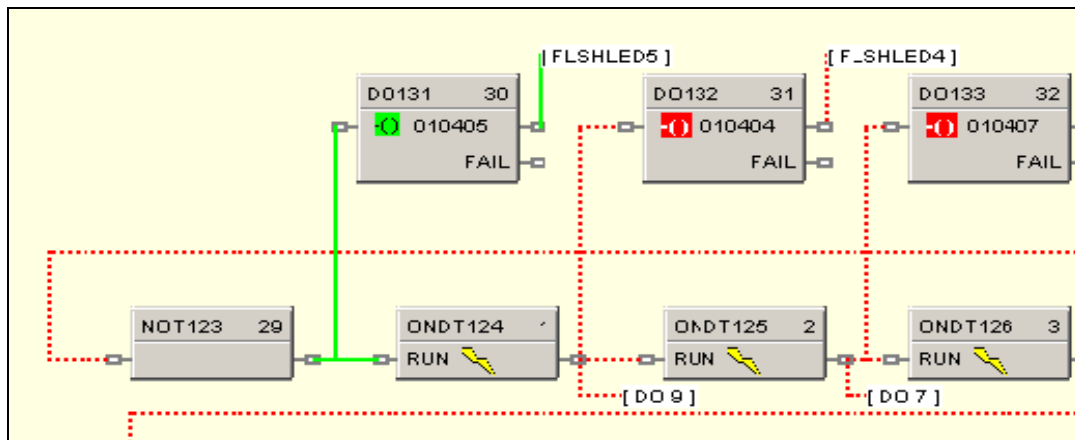

Figure 4 - Logic power flow

### On-Line Monitoring Features (cont'd)

- User-selected Watch Window.** Allows access to digital and analog I/O, Signal Tags, Variables), and custom display data groups by tab selection. A custom Watch Window may also be created by selecting parameters from the configuration diagram. Write capability from Watch Windows is supported. Variables on the safety worksheet must be enabled and restricted to non-critical safety functions for writing while operating in the safe mode. Writes are then enabled utilizing the associated Write Variables function (WVAR) located on the process worksheet.

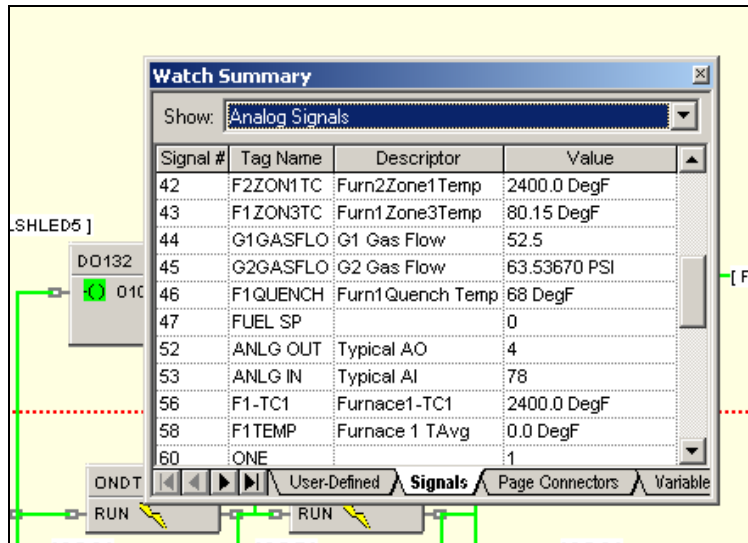

Figure 5 - User defined watch window

- Dynamic function blocks input and output values.** Provided when monitoring the function blocks of the configuration diagram, the dynamic value presentation may be limited to a single pin, a single function block, or it may encompass the entire display window.

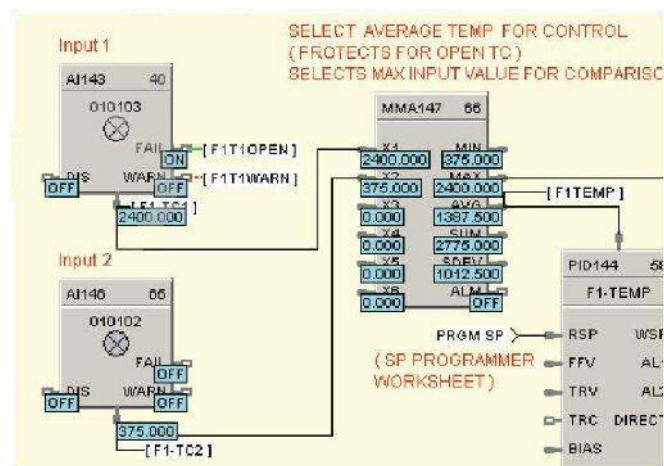

Figure 6 - Dynamic function block values

- Signal Trace-back for any function block input.** Used to find the signal source for quick identification of potential errors.
- FIND.** A FIND function allows location of multiple instances of specific tags across all worksheets.

## On-Line Monitoring Features (cont'd)

- Recipe Management.** A separate Recipe Management feature allows creating, editing, copying and exporting recipes, profiles, schedules and sequences to allow transferring this information between configurations and controllers.
- Diagnostic Monitoring.** Provided in the Utilities section of the software to view controller status, I/O rack status and communication port diagnostics status for both serial and network ports. A search function to locate/force/unforce function blocks is also provided.

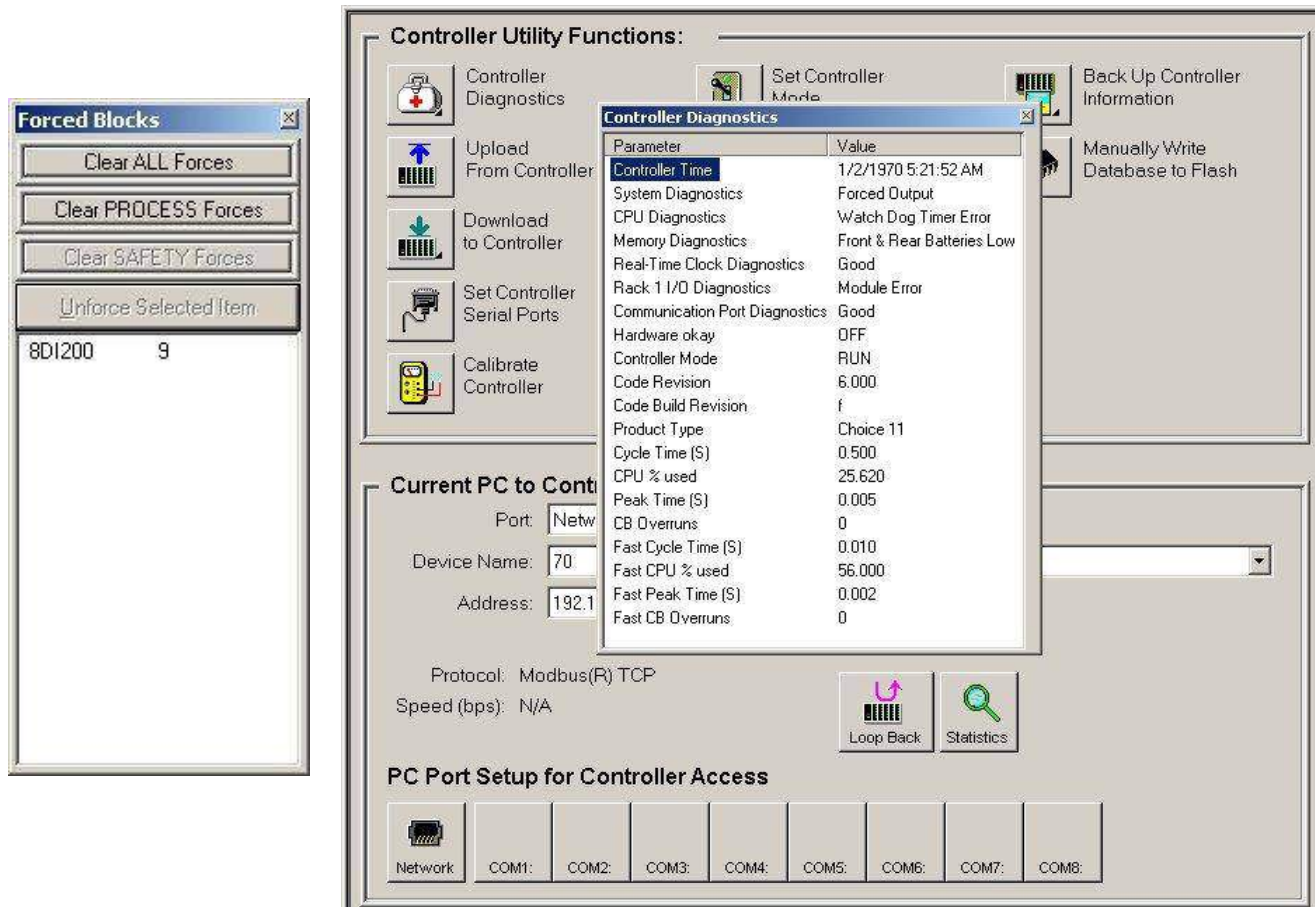

Figure 7 - Forced blocks window (left), Diagnostic monitoring window

## 900 Control Station

When configuring 900 Control Station, the configuration file from Controller Designer is imported into Station Designer software to simplify database management when building displays. Database mismatches between the controller and operator interface configurations are detected at run-time of the interface.

## Remote Access

Controller Designer software supports remote access to ControlEdge HC900 Controllers via Modem using Modbus Protocol or Honeywell's ELN Protocol. To support this function, an external modem must be connected to the serial port of the remote controller. Controller Designer software provides a calling list facility to simplify access. Selecting Modem communications from the Utilities tab and requesting a dial up operation provides the user with a calling list to access the appropriate controller. Once communications is established, the configuration of the controller may be uploaded to the PC and edited or monitored remotely.

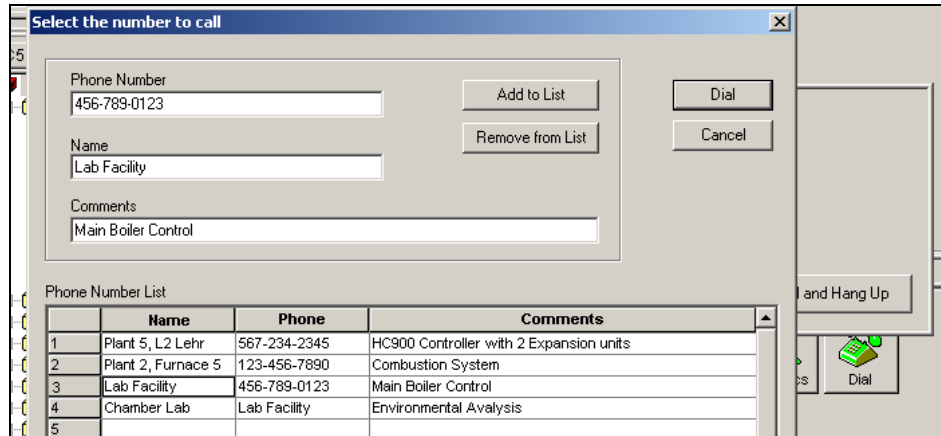

Figure 9 - Remote access dialup

## File Export for database transfer

When interfacing the ControlEdge HC900 controller to PC software programs or 3rd party operator interfaces, a time saving service is provided to export tag and variable definitions in CSV or tab delimited formats. In addition, the Modbus addresses of each configured data parameter may also be exported to a file.

A11		Hex Addr									
	A	B	C	D	E	F	G	H	I	J	
1	RevisionID:	5500.0032.0005.0002.0008									
2	File Name:	HC900-C70 Rev 4.1x : HC900 Standard Demo C70_4.1.cde *									
3	Controller Name:	FURNACE1									
4	Title:	Demo Configuration									
5	Author:	R. Zeigler, R. Pistoll									
6	Created Date:	#####									
7	Modified Date:	#####									
8											
9	Report Title:	All Modbus Registers Report									
10											
11	Hex Addr	Dec Addr	Partition Name	Tag Name	Description	Type	#	Data Type	Access	EU	
12	0x0000		1 Misc_Parameters	Instrument_Mode		System Register		unsigned 16	R/W		
13	0x0002		3 Misc_Parameters	Load_Recipe		System Register		unsigned 16	W		
14	0x0004		5 Misc_Parameters	Reserve_Status_C70R_Only		System Register		unsigned 16	R		
15	0x0040		65 Loops_1_24	F2_ZONE1.PV	PV	PID		float 32	R		
16	0x0042		67 Loops_1_24	F2_ZONE1.RSP_SP2	RSP SP2	PID		float 32	R/W		
17	0x0044		69 Loops_1_24	F2_ZONE1.WSP	WSP	PID		float 32	R/W		
18	0x0046		71 Loops_1_24	F2_ZONE1.Output	Output	PID		float 32	R/W		
19	0x0048		73 Loops_1_24	F2_ZONE1.PV_B	PV (B)	PID		float 32	R		
20	0x004C		77 Loops_1_24	F2_ZONE1.Gain_1_Prop_Band_1	Gain 1 Prop Band 1	PID		float 32	R/W		
21	0x004E		79 Loops_1_24	F2_ZONE1.Direction	Direction	PID		float 32	R		
22	0x0050		81 Loops_1_24	F2_ZONE1.Reset_1	Reset 1	PID		float 32	R/W		
23	0x0052		83 Loops_1_24	F2_ZONE1.Rate_1	Rate 1	PID		float 32	R/W		
24	0x0054		85 Loops_1_24	F2_ZONE1.Scan_Cycle_Time	Scan Cycle Time	PID		float 32	R		
25	0x0056		87 Loops_1_24	F2_ZONE1.PV_Low_Range	PV Low Range	PID		float 32	R		
26	0x0058		89 Loops_1_24	F2_ZONE1.PV_High_Range	PV High Range	PID		float 32	R		
27	0x005A		91 Loops_1_24	F2_ZONE1.Alarm_1_SP1	Alarm 1 SP1	PID		float 32	R/W		

Figure 10 - File Export



## Controller Designer Software Reports

Documenting your configuration is supported through a variety of report formats. Each can be print-previewed. A few of these include a summary of the controller I/O used, function block worksheet selection (each page of diagram worksheet printed as 8.5 x 11" sheet), function block properties, tag parameters, recipe listings, setpoint profile listings, sequencer listings, setpoint scheduler listings, OI display groups, and controller setup. For signal tracing, a Where Used list is also provided.

File Name: HCP90-C50 Rev 6.0x : All communications *		Title: Demo Configuration		Author: R. Zeigler, R. Pistoll	
<b>Where Used Report [Process &amp; Safety]</b>					
<b>SOURCE:</b>			<b>WHERE USED:</b>		
HOPS		Process: Sequencing	01		
JOG		Process: Vacuum Furnace	01	VAC_SPP	Process: Vacuum Furnace 01
LIGHTS		Process: Logic/Timing	05		
LOPRESS	Low Pressure	Process: I/O	01		
LO_AIRFLO		Process: Extended Boiler	02	MATH283	Process: Extended Boiler 02
				MATH292	Process: Extended Boiler 03
LO_GASFLO		Process: Extended Boiler	03	MATH286	Process: Extended Boiler 03
LO_OILFLO		Process: Extended Boiler	03	MATH286	Process: Extended Boiler 03
LS1	Limit Switch 1	Process: Logic/Timing	02		
LS2	Limit Switch 2	Process: Logic/Timing	02		
LS4	Limit Switch 4	Process: I/O	01		
LS5	Limit Switch 5	Process: I/O	01		
LS6	Limit Switch 6	Process: I/O	01	AND187	Process: Logic/Timing 01
LS7	Limit Switch 7	Process: I/O	01	AND187	Process: Logic/Timing 01
M3MOTOR	M3 Motor Drive	Process: Logic/Timing	01		
M3STOPPB	Motor 3 Stop PB	Process: I/O	01	LTCH195	Process: Logic/Timing 01
				AND197	Process: Logic/Timing 01
M3STRTPB	Motor 3 Start PB	Process: I/O	01	LTCH195	Process: Logic/Timing 01
				OR198	Process: Logic/Timing 01
M3_MOTOR		Process: Logic/Timing	01		
MANUAL_AIR		Process: Extended Boiler	03	OXYTRIM	Process: Extended Boiler 03
MCBAIR		Process: Extended Boiler	03	MATH283	Process: Extended Boiler 02
				COMB_AIR	Process: Extended Boiler 03
				MATH292	Process: Extended Boiler 03
				COMB GAS	Process: Extended Boiler 02
				MATH286	Process: Extended Boiler 03
				TOT303	Process: Extended Boiler 04
				CMR234	Process: Logic/Timing 04
MGAS		Process: Extended Boiler	04		
MINUTES		Process: Logic/Timing	04		
MIX		Process: Sequencing	01		
MIXSPEED		Process: Sequencing	01		
MODE		Process: Sequencing	01		
MOIL		Process: Extended Boiler	02	MATH286	Process: Extended Boiler 03
MOXY		Process: Extended Boiler	03	OXYTRIM	Process: Extended Boiler 03
MPRESSURE		Process: Extended Boiler	04	HEADPRESS	Process: Extended Boiler 02
MSTEAM_FLOW		Process: Extended Boiler	04	MATH284	Process: Extended Boiler 01
				SUB288	Process: Extended Boiler 01
NET_TIME_SERVER		Process: Logic/Timing	04		
NEW_START		Process: Alarms & Monitoring	02	OR342	Process: Alarms & Monitoring 01
O2_FGEN		Process: Extended Boiler	04	OXYTRIM	Process: Extended Boiler 03
OILMAN		Process: Extended Boiler	02	MDFL279	Process: Extended Boiler 02
OIL_VALVE		Process: Extended Boiler	02	SCB282	Process: Extended Boiler 02
ON		Process: Pump Control	05	SPP343	Process: Pump Control 05
OR_SW1	Override SW1	Process: I/O	01		
OXY		Process: Extended Boiler	03	SCB285	Process: Extended Boiler 03
OXY_TRIM		Process: Extended Boiler	03	DIV278	Process: Extended Boiler 02
<b>Created Date:</b> 9/21/2001 8:31:17 PM		<b>Modified Date:</b> 8/1/2013 11:26:58 AM		<b>Page:</b> 11 of 30	

Figure 11 - Sample Where Used Report

## Version Control

The Version Control System provides capabilities to save changes made to the cde and non cde files over time and creates repositories to manage different versions.

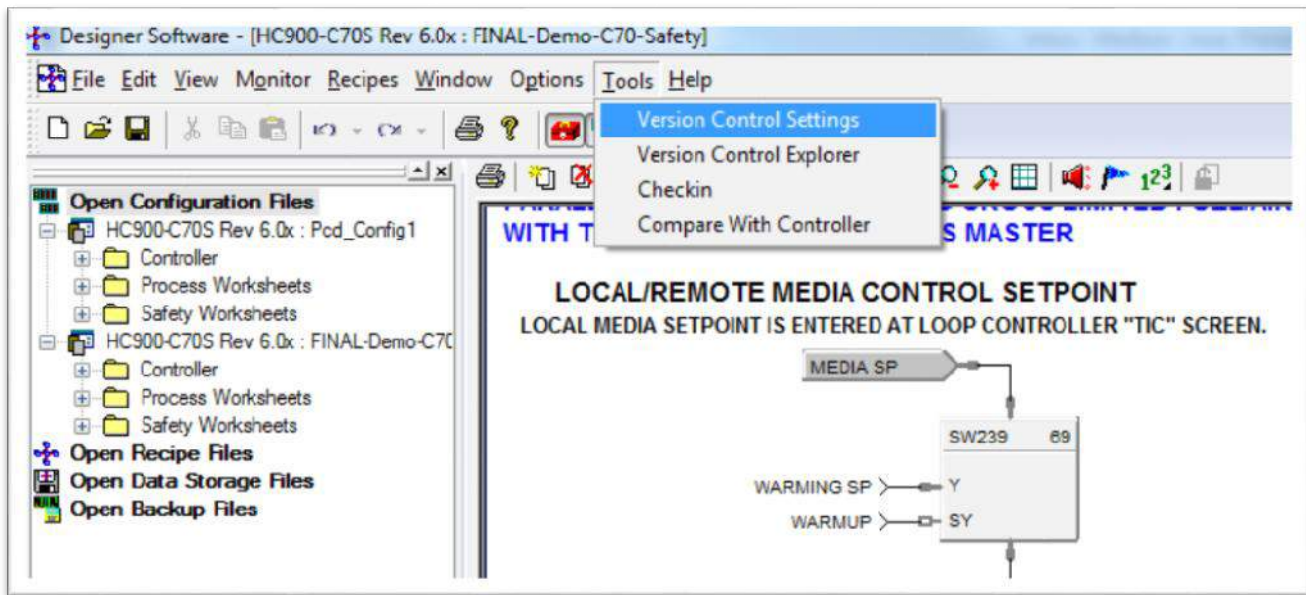

This helps to manage, track, and compare differences between two revisions.

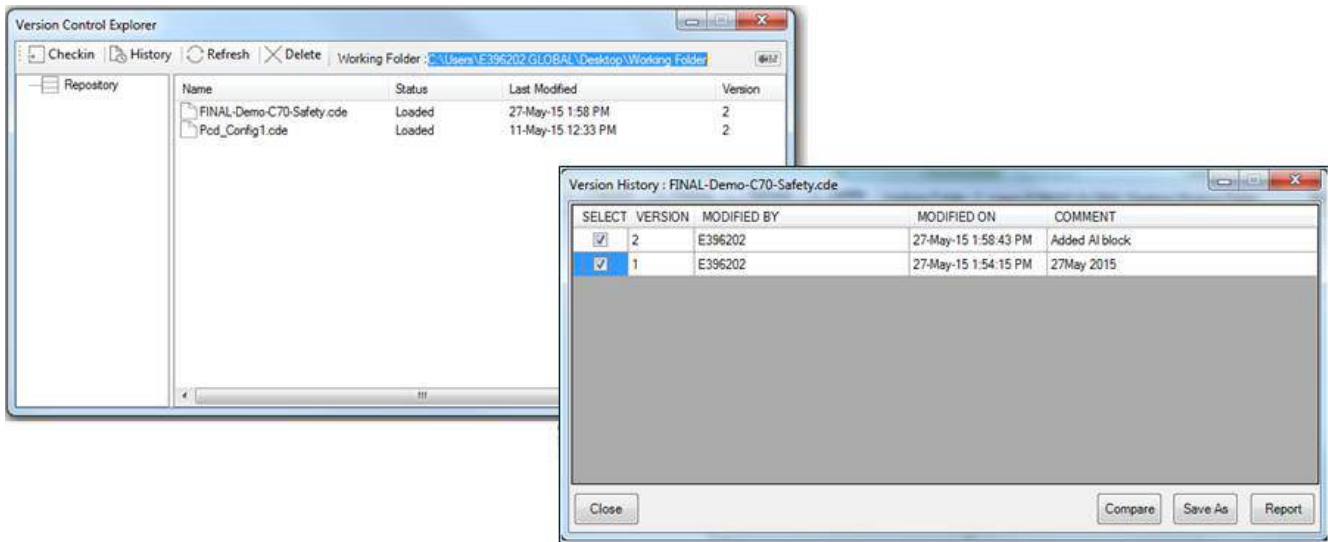

## Report summary

The report provides details of compared data between two files or versions. The data is classified and presented under different categories such as Controller, Process, Safety, and Difference Summary. This report can be exported to Microsoft Excel file and used for future references.

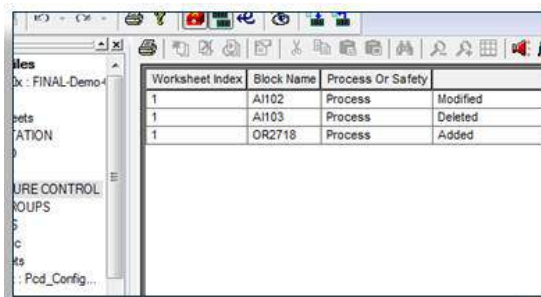

Worksheet Index	Block Name	Process Or Safety	Modified
1	AI102	Process	Modified
1	AI103	Process	Deleted
1	OR2718	Process	Added

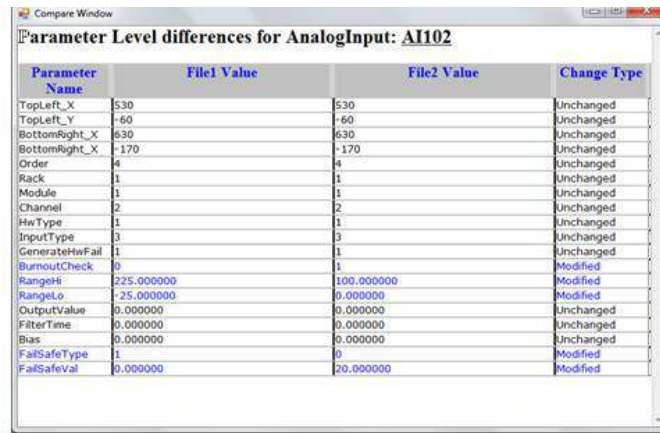

Parameter Name	File1 Value	File2 Value	Change Type
TopLeft_X	530	530	Unchanged
TopLeft_Y	-60	-60	Unchanged
BottomRight_X	630	630	Unchanged
BottomRight_Y	-170	-170	Unchanged
Order	4	4	Unchanged
Rack	1	1	Unchanged
Module	1	1	Unchanged
Channel	2	2	Unchanged
HWType	1	1	Unchanged
InputType	3	3	Unchanged
GenerateHwFail	1	1	Unchanged
BurnoutCheck	0	1	Modified
RangeHi	225.000000	100.000000	Modified
RangeLo	-25.000000	0.000000	Modified
OutputValue	0.000000	0.000000	Unchanged
FilterTime	0.000000	0.000000	Unchanged
Bias	0.000000	0.000000	Unchanged
FailSafeType	1	0	Modified
FailSafeVal	0.000000	20.000000	Modified

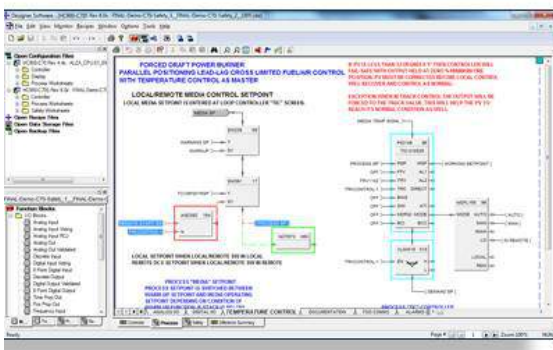

## Paste special functionality

This window allows the user to find and replace text and add a prefix or suffix to the item names. This will help to maintain consistency across the item names.

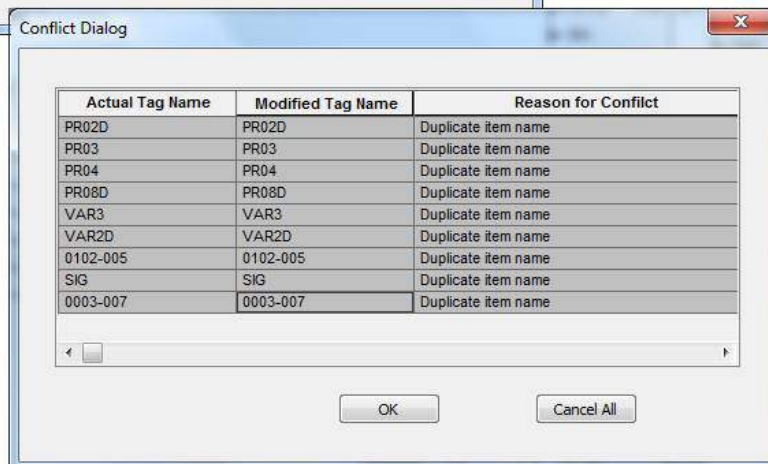
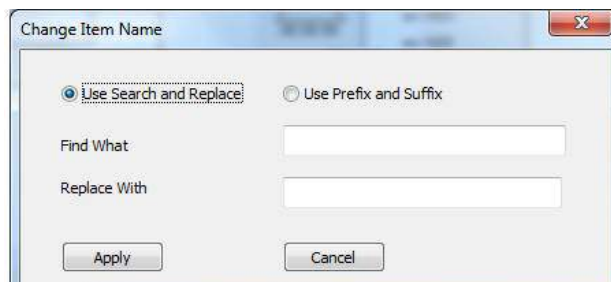

Actual Tag Name	Modified Tag Name	Reason for Conflict
PR02D	PR02D	Duplicate item name
PR03	PR03	Duplicate item name
PR04	PR04	Duplicate item name
PR08D	PR08D	Duplicate item name
VAR3	VAR3	Duplicate item name
VAR2D	VAR2D	Duplicate item name
0102-005	0102-005	Duplicate item name
SIG	SIG	Duplicate item name
0003-007	0003-007	Duplicate item name

## Find and Replace

The **Find and Replace** feature allows the user to identify specific tags and replace them in all instances at the same time.

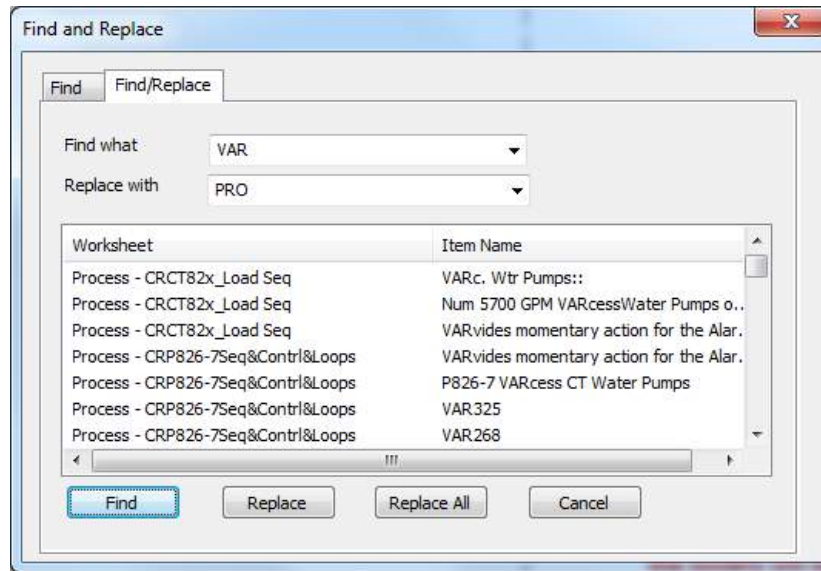

## Library Functionality

This functionality helps to export a group of the control logic and thereby save to a location. These groups can be imported in the worksheet whenever required. This saves time spent in recreating the control logics again. It is easy to share and reuse by other users via the designer software.

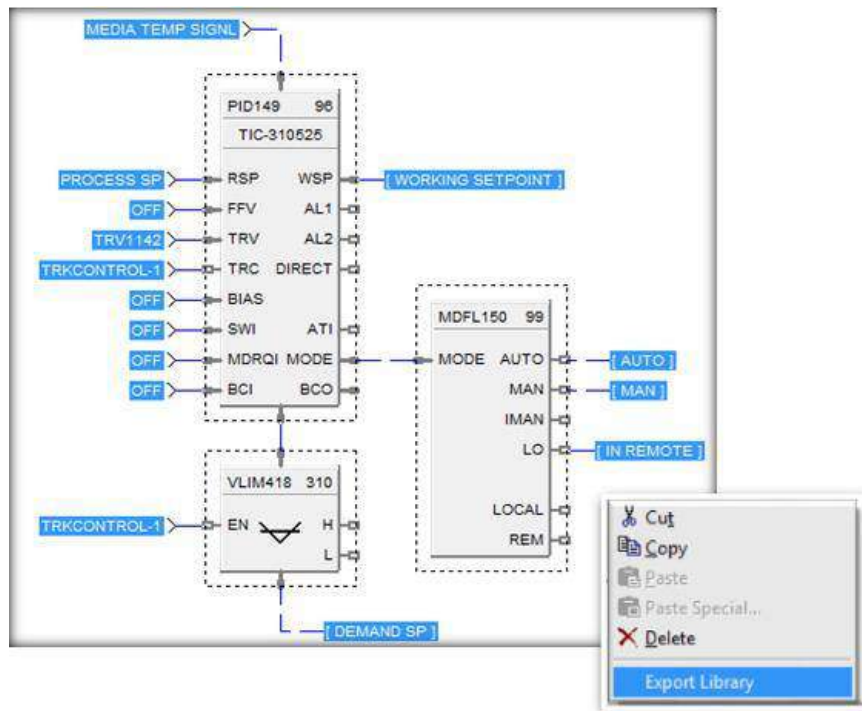

## Help

Controller Designer provides extensive user help in the form of topical help information that may be accessed from the Help selection on the main menu. Help information in this section cover subjects from how to get started to extensive detail on each function block. See Figure 12.

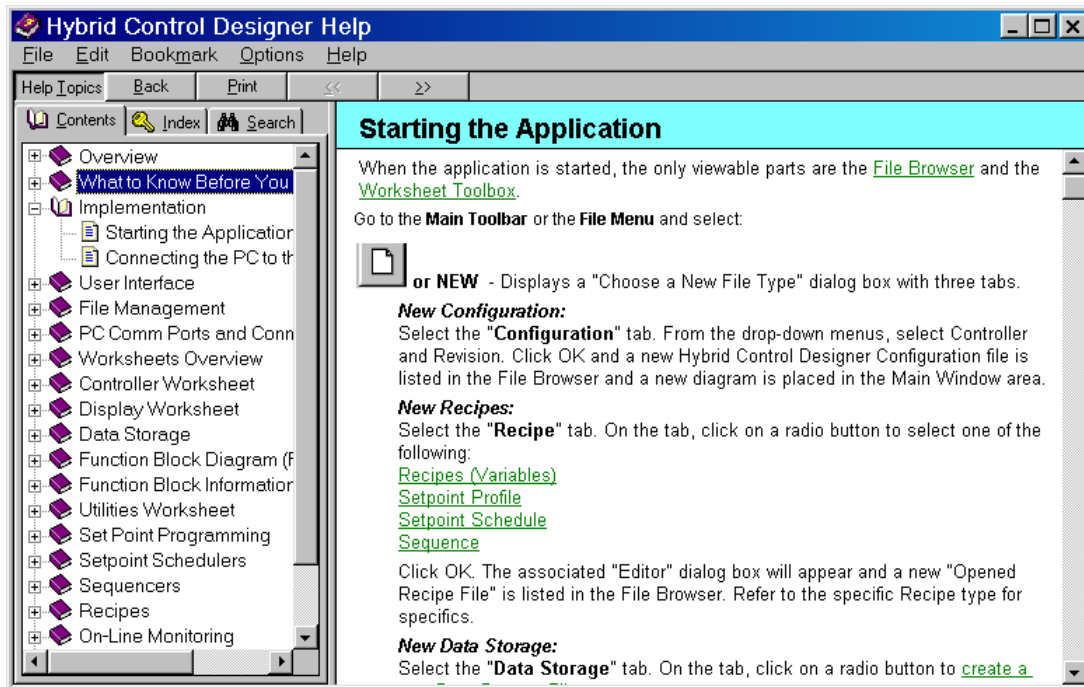

Figure 12 - Topic help

Topic help specific to each function block is available. See Figure 13.

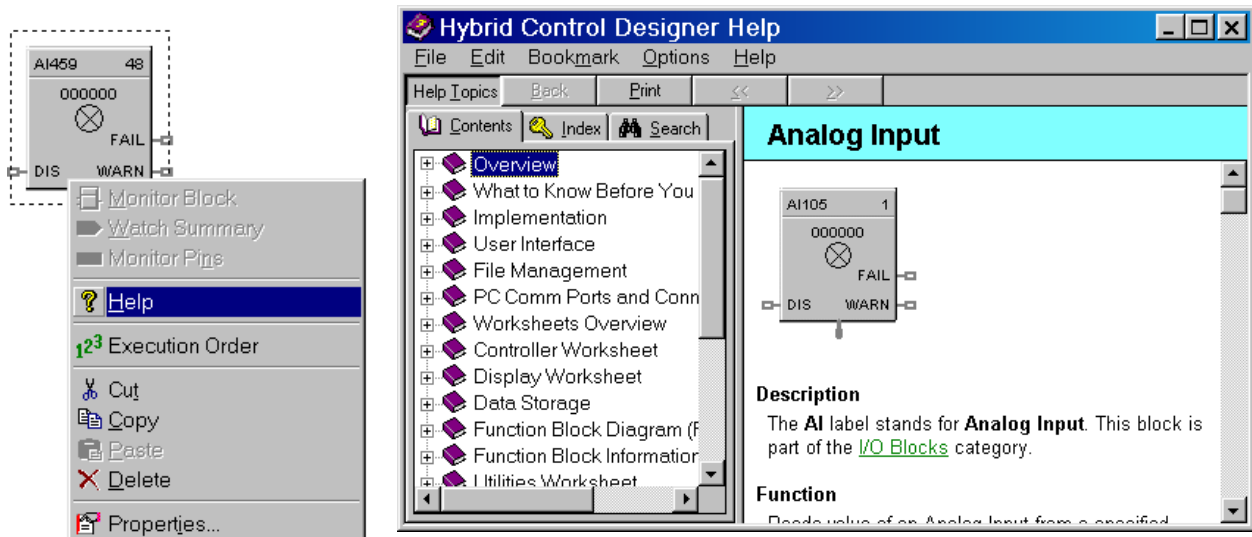

Figure 13 - Right-clicking on an AI block (L) to access its help (R)

## Help (Continued)

Pop-up help for entry fields is available. See Figure 14.

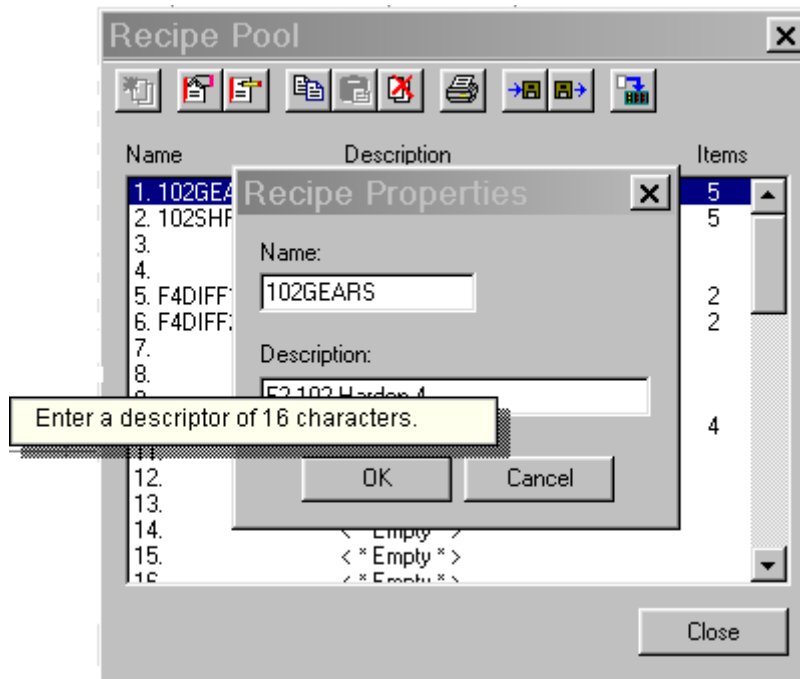

Figure 14 - Right-clicking on a recipe description to see its pop-up help

## ControlEdge HC900 Controller Utilities Software

HC Utilities is a separate optional PC software application that provides many of the user maintenance and diagnostic functions of HC Designer software but restricts configuration changes. This software is an ideal program for OEMs and Integrators who wish to provide a maintenance program to their customers without the risk of unauthorized changes to the controller's program.

Files created in HC Utilities for Recipes, and Data Storage schedules may be loaded into the system via serial communications, network communications.

The serial and network interface capabilities also allow users to download new controller configurations or perform equipment firmware upgrades.

Features include:

- Recipe development: (Variables, Setpoint Profiles, Setpoint Schedules, Sequences)
- Data storage schedules
- Set controller communication ports
- Calibrate controller I/O
- Configuration reloads
- Firmware Upgrades
- View controller diagnostics
- Monitor controller configurations of unlocked worksheets

## Specifications

TABLE 1 – ControlEdge HC900 Controller Designer & Controller Utilities Software Specifications	
<b>Design</b>	
<b>PC Requirements</b>	Software runs on Windows™ 7 (32 & 64 bit OS) or Windows 10 (32 & 64 bit OS) Minimum—Pentium Class 1.5 GHz with 1 GB of RAM (2.5 GHz with 4GB with multi core is recommended for better performance) Screen resolution – SVGA (1024x768 recommended) or better
<b>Configuration (HC Designer only)</b>	Off-line configurations with optional on-line (Run mode) configuration download.
<b>Monitoring</b>	On-line monitoring allows user to test the developed configuration.
<b>System Interconnection</b>	Connected to controller through its Ethernet 10/100 Base-T host ports, RS485 port. <i>Maximum Distance for Ethernet Connection:</i> Not limited, per user network topology <i>Cable termination:</i> RJ-45
<b>Modem</b>	<p><i>PC Interface:</i> Supports Microsoft Windows Telephony API (TAPI) device independent modem communications. Baud rate = 1200 to 56.6KB selectable</p> <p><i>Controller Interface:</i> Connects to the controller configuration port. <i>Most commercially available modems with equivalent specifications to those validated should function with the ControlEdge HC900 controller.</i> The following modems have been validated: 3COM US Robotics 56K Data/Fax External Modem, Zoom 56K Dual mode External Modem, Best Data 56SX Data Fax External Modem</p> <p>The modem must have the following capabilities:</p> <ul style="list-style-type: none"> <li>• Auto answer</li> <li>• Can operate at 1200 baud, 8 data bits, 1 stop bit, and no parity</li> <li>• Hardware handshaking can be disabled</li> <li>• Software handshaking can be disabled</li> <li>• Data Terminal Ready (DTR) input can be disabled</li> <li>• Result codes can be suppressed</li> <li>• Echo can be disabled</li> <li>• Must be equipped with non-volatile memory (NVRAM) so that settings that are configured using command strings can be retained during a power-outage</li> <li>• Must be able to load the NVRAM settings automatically on power-up</li> </ul>

<b>TABLE 2 ControlEdge HC900 Controller Designer &amp; Controller Utilities Software Functions</b>	
<b>Controller CPUs supported</b>	C30, C50, C70 and C75
<b>Controller Firmware Version Supported</b>	Software version number must be equal to or a higher number than the controller firmware version number
<b>Configuration File Conversions</b>	Can convert between certain versions or CPU types.
<b>Recipe Development</b>	<p>Recipes may be developed for Setpoint Profiles, Setpoint Schedules, Variables and Sequences.</p> <p>Recipes may be stored as separate files, downloaded to a controller and/or printed for a hard copy record.</p>
<b>Data Storage Schedules</b>	<p>Data Storage schedules in the controller may be developed using a dedicated type of function block. Data files are accessed via communications using HC Historian software.</p> <p>ControlEdge HC900 Supports History Backfill when used along with Experion HS</p> <ul style="list-style-type: none"> <li>• Benefit: - Critical Data Protection and Compliance</li> <li>• Target: - customers with critical data needs; aerospace manufacturing for complete records of the complete manufacturing process, food &amp; beverage where accurate data on manufacturing and warehousing is required, pilot plants for accurate data retention of processes for new product documentation, data centres.</li> <li>• Secures critical customers from: <ul style="list-style-type: none"> <li>– Network outage or communication glitches</li> <li>– Experion HS server outages, shutdowns, MS updates</li> </ul> </li> <li>• At all other times, the Experion HS history database remains the master</li> <li>• Backfills ONLY occur when plant data is missing</li> </ul>
<b>Security</b>	Password security may be applied to the entire configuration file and/or to individual worksheets within a file. Default security may be disabled for worksheets.
<b>Concurrent operation</b>	One instance of HC Designer or HC Utilities per PC at a time
<b>Printing</b>	<p>The following are available for printing: Controller (hardware and email assignments)</p> <p>Function Block diagram (Process and/or Safety worksheets, block parameters, Modbus registers, tags, where-used list, statistics)</p> <p>Display (display settings, help screens, display key assignments, data storage schedule)</p> <p>Recipes (variables, setpoint profiles, setpoint schedules, sequences)</p> <p>Alarm and Event groups</p>
<b>Export Files</b>	<p>Format – CSV, Comma delimited or Tab delimited</p> <p>Types: Controller – (I/O)</p> <ul style="list-style-type: none"> <li>Function block Modbus Register Map</li> <li>Function block tags</li> <li>Recipes</li> </ul>
<b>Controller maintenance</b>	<p>Calibration – Analog Input Modules</p> <ul style="list-style-type: none"> <li>TC Cold junction</li> <li>Analog Output Modules</li> <li>Position Proportional Output function blocks</li> </ul> <p>Set controller time</p> <p>Serial Port setup</p> <p>Perform controller firmware upgrades</p>



**TABLE 3 Summary of ControlEdge HC900 Controller Designer & Controller Utilities Software Main Window Menu Selections**

Main Menu Selection	Description
<b>File</b>	<ul style="list-style-type: none"> <li>• <i>New</i>: Provides dialog box</li> <li>• <i>Open</i>: Opens an existing Controller Designer configuration.</li> <li>• <i>Close</i>: Closes the active window.</li> <li>• <i>Save</i>: Saves the active configuration.</li> <li>• <i>Save As</i>: Can name the active configuration, select the target CPU type and revision and select the directory where file is to be stored.</li> <li>• <i>Download</i>: Alternate selection for download of saved configuration</li> <li>• <i>Upload</i>: Alternate selection for upload of complete configuration in controller including graphic pages, text annotations, stored recipes/profiles/schedules/sequences, OI display assignments, OI data storage setup</li> <li>• <i>Upload Recipes</i>: Uploads individual recipe files for variables, setpoint profiles, setpoint schedules and sequences. (Allows print, save, edit or download.)</li> <li>• <i>Backup controller</i>: Saves backup configuration file. cbk.</li> <li>• <i>Properties</i>: File properties, statistics (capacity usage), file read protection, worksheet protection (password access to individual worksheets)</li> <li>• <i>Write Protect File</i>: Can enter and confirm a password for the selected file.</li> <li>• <i>Print Report</i>: Provides report printout selections for documentation including configured I/O list, worksheets, block parameters, tag list, display listing, recipes, SP profiles, SP schedules, sequences, alarms and event list.</li> <li>• <i>Print Report Preview</i>: Provides print preview of report selection plus print selection</li> <li>• <i>Printer Setup</i>: Can select printer, paper type, and orientation.</li> <li>• <i>Exit</i>: Exits the Controller Designer application.</li> </ul>
<b>Edit (HC Designer only)</b>	<ul style="list-style-type: none"> <li>• <i>Undo/redo</i>: undo/redo last edit</li> <li>• <i>Cut, Copy, Paste</i>: Editing functions for function block diagram items.</li> <li>• <i>Delete</i>: Deletes the currently selected item on the function block diagram.</li> <li>• <i>Append FBD (Function Block Diagram) Worksheet</i>: Adds a worksheet</li> <li>• <i>Delete FBD Worksheet</i>: Deletes a worksheet and its contents</li> <li>• <i>Reorder FBD</i>: Allows the sequence of worksheets to be changed.</li> <li>• <i>Worksheet properties</i>: Adds title and description for worksheet</li> <li>• <i>Unlock Worksheet</i>: Allows entry of password to unlock protected worksheet</li> <li>• <i>Block and Tag Order</i>: Shows list for ordering block sequence (fast and normal scan rates), ordering of major blocks such as control loops for display purposes</li> <li>• <i>Loop Mode Priority</i>: Lets you select which has priority: Manual Mode or Tracking Mode.</li> <li>• <i>Alarms</i>: Displays alarm groups for setup or changes</li> <li>• <i>Events</i>: Shows tag listing for assignment and annunciation as reportable events</li> <li>• <i>Edit Fixed Modbus Register Map</i>: Allows limited editing of pre-assigned (fixed) Modbus addresses.</li> <li>• <i>Configure Modbus Map Type</i>: For extensive Modbus address editing, select this to change from fixed map to custom map.</li> <li>• <i>Defragment Function Block List</i>: Frees up memory consumed by previously deleted function blocks.</li> <li>• <i>Find</i>: Directs to area of diagram for tagged variables and blocks.</li> <li>• <i>Go To</i>: Can enter the page number of Worksheet to which you want to go.</li> <li>• <i>Options</i>: Warning Level: Can enable or disable the Open Input and Unassigned I/O warnings on download. Default Annotation Attributes: Sets the default text attributes for annotation entries.</li> </ul>
	<ul style="list-style-type: none"> <li>• <i>Toolbar</i>: Displays or hides the toolbar in the top of the Main window.</li> </ul>

**TABLE 3 Summary of ControlEdge HC900 Controller Designer & Controller Utilities Software Main Window Menu Selections**

Main Menu Selection	Description
<b>View</b>	<ul style="list-style-type: none"> <li>• <i>Status Bar</i>: Displays or hides the status bar at the bottom of the Main window.</li> <li>• <i>File Browser</i>: Displays all open files (configurations, recipes, data storage)</li> <li>• <i>Worksheet Toolbox</i>: Enables function block diagram tool category listing</li> <li>• <i>Trace Window</i>: Shows listing of connection routing for selected input pin to function block</li> <li>• <i>Localization</i>: For switching between supported languages by HCD tool</li> <li>• <i>Phone Book</i>: Shows editable list of phone numbers</li> <li>• <i>Grid</i>: Can place a grid in the function block diagram.</li> <li>• <i>Zoom Out</i>: Can zoom out to see more of a document (5 levels).</li> <li>• <i>Zoom Normal</i>: Returns object to normal size (Zoom In).</li> </ul>
<b>Monitor</b>	<ul style="list-style-type: none"> <li>• <i>Monitor Mode</i>: Enables monitor mode. Enables toolbar for monitoring selections</li> <li>• <i>Monitor Toolbar</i>: Disables/Enables monitoring toolbar</li> <li>• <i>Set Update Rate</i>: Provides monitoring update rate selection – ¼ sec., ½ sec., 1 sec., and 5 sec.</li> <li>• <i>Set Logic State Colors</i>: Select a color scheme for indicating the on/off status of digital wires, digital signal tags, page connectors, and logic inversion.</li> <li>• <i>Watch Summary Window</i>: Enables watch window with tabbed selection of I/O, Signal Tags, Variables (write-capable), and display groups (write-capable) . Writes are restricted from running in Safe "RUN" mode unless enabled for non-critical safety functions located on the safety worksheet. Writes are preformed using the Write Variable (WVAR) on the process worksheet and connected to the associated variable in the safety worksheet.</li> <li>• <i>Controller Diagnostics</i>: Displays controller diagnostics. • <i>Rack Diagnostics</i>: Displays rack and I/O diagnostics.</li> <li>• <i>Controller Ports Diagnostics</i>: Provides menu selection of all ports for displaying diagnostic status including Ethernet port, RS-485 port, Host connections, Expansion Rack port, Peer to peer connections</li> <li>• <i>Modbus Port Diagnostics</i></li> <li>• <i>Monitor Function Block</i>: Alternate selection for enabling function block monitoring</li> <li>• <i>Forced Blocks</i>: Displays all blocks with force conditions</li> <li>• <i>Show/Hide All Function Block Windows</i>: Allows monitored blocks to be disabled/enabled for viewing</li> <li>• <i>Show/Hide All Pin Data</i>: Displays monitoring values (numeric or On/Off state) at any input or output pin</li> <li>• <i>Show/Hide All Monitor Windows</i>: Allows all monitoring windows to be disabled/enabled for viewing</li> </ul>

**TABLE 3 Summary of ControlEdge HC900 Controller Designer & Controller Utilities Software Main Window Menu Selections**

Main Menu Selection	Description
<b>Recipes</b>	<ul style="list-style-type: none"> <li>• <i>Allocate Recipe Memory</i>: Allocates memory in controller to allow for more or fewer recipes in the four pools below.</li> <li>• <i>Recipes (Variables)</i>: Displays recipe pool, allows stored recipe review, supports recipe development, recipe printout is selectable</li> <li>• <i>Setpoint Profiles</i>: Displays setpoint profile pool, allows stored profile review, supports profile development, profile printout is selectable</li> <li>• <i>Setpoint Schedules</i>: Displays setpoint schedules, allows stored schedule review, supports schedule development, schedule printout is selectable</li> <li>• <i>Sequences</i>: Displays sequence pool, allows stored sequencer review, supports sequencer development, sequence printout is selectable</li> </ul>
<b>Window</b>	<ul style="list-style-type: none"> <li>• <i>Cascade</i>: Arranges windows so that they overlap.</li> <li>• <i>Tile Horizontally</i>: Arranges windows over and under each other. Each window is visible and none overlap.</li> <li>• <i>Tile Vertically</i>: Arranges windows side by side. Each window is visible and none overlap.</li> <li>• <i>Arrange All</i>:</li> </ul>
<b>Version Control</b>	<ul style="list-style-type: none"> <li>• <i>Version Control Settings</i>: Creates or uses existing repository and working folder.</li> <li>• <i>Version Control Explorer</i>: Shows the folder structure and status of the files in the working folder.</li> <li>• <i>Checkin To Version Control</i>: Stores the changes from the working folder to repository folder.</li> <li>• <i>Compare</i>: Compares differences between two revisions of the cde file.</li> </ul>
<b>Help</b>	<ul style="list-style-type: none"> <li>• <i>Help Topics</i>: Calls up the top-level Help Contents page.</li> <li>• <i>About Help</i>: Displays copyright and software version information.</li> </ul>

**TABLE 4 ControlEdge HC900 Controller Designer Functional Tabs**

<b>Tab</b>	<b>Description</b>
<b>Controller</b>	Displays the I/O used in configuration by rack, module, channel. Supports configuration of: <ul style="list-style-type: none"> <li>• Controller name (for network peer addressing)</li> <li>• E-mail alarm setup</li> </ul>
<b>Display</b> (for support of legacy 559 and 1042 OI functionality) Available for configurations prior to version 6.000	Displays the 559 and 1042 operator interface setup. Supports configuration of: <ul style="list-style-type: none"> <li>• Operator interface displays (for example: trends, horizontal or vertical bars)</li> <li>• Alarms</li> <li>• Events</li> <li>• Operator interface security</li> <li>• Filenames</li> <li>• Help displays</li> <li>• Startup display</li> </ul>
<b>Function Blocks</b>	Supports configuration of control and data acquisition strategy using function blocks available from category tree. Up to 40 named worksheets with 20 pages each can be assigned.
<b>Modbus Map</b>	Appears when using a custom Modbus map. Custom Modbus map lets you assign blocks and parameters to custom addresses rather than pre-assigned fixed Modbus addresses.
<b>Utilities</b>	Supports configuration of: <ul style="list-style-type: none"> <li>• PC communications ports (Com1 – Com8), selectable controller IP addresses</li> <li>• Controller communications ports and IP address setup with auto-detect/verification selection</li> <li>• Real-time clock, controller mode</li> <li>• Other functions:               <ul style="list-style-type: none"> <li>• Controller, I/O, controller communications port, peer controller diagnostics</li> <li>• Analog I/O calibration</li> <li>• Slidewire calibration (Position Proportional Output)</li> <li>• Show I/O force conditions (HC Designer only)</li> </ul> </li> <li>• Upload, Download and Loop-back check functions</li> </ul>

**Warranty/Remedy**

Honeywell warrants goods of its manufacture as being free of defective materials and faulty workmanship. Contact your local sales office for warranty information. If warranted goods are returned to Honeywell during the period of coverage, Honeywell will repair or replace without charge those items it finds defective. The foregoing is Buyer's sole remedy and is **in lieu of all other warranties, expressed or implied, including those of merchantability and fitness for a particular purpose.**

Specifications may change without notice. The information we supply is believed to be accurate and reliable as of this printing. However, we assume no responsibility for its use.

While we provide application assistance personally, through our literature and the Honeywell web site, it is up to the customer to determine the suitability of the product in the application.

## Sales and Service

For application assistance, current specifications, pricing, or name of the nearest Authorized Distributor, contact one of the offices below.

### ASIA PACIFIC

Honeywell Process Solutions,  
(TAC) [hfs-tac-support@honeywell.com](mailto:hfs-tac-support@honeywell.com)

#### Australia

Honeywell Limited  
Phone: +(61) 7-3846 1255  
FAX: +(61) 7-3840 6481  
Toll Free 1300-36-39-36  
Toll Free Fax:  
1300-36-04-70

#### China – PRC - Shanghai

Honeywell China Inc.  
Phone: (86-21) 5257-4568  
Fax: (86-21) 6237-2826

#### Singapore

Honeywell Pte Ltd.  
Phone: +(65) 6580 3278  
Fax: +(65) 6445-3033

#### South Korea

Honeywell Korea Co Ltd  
Phone: +(822) 799 6114  
Fax: +(822) 792 9015

### EMEA

Honeywell Process Solutions,  
Phone: + 80012026455 or  
+44 (0)1344 656000

Email: (Sales)

[FP-Sales-Apps@Honeywell.com](mailto:FP-Sales-Apps@Honeywell.com)

or

(TAC)

[hfs-tac-support@honeywell.com](mailto:hfs-tac-support@honeywell.com)

### AMERICA'S

Honeywell Process Solutions,  
Phone: (TAC) 1-800-423-9883 or  
215/641-3610  
(Sales) 1-800-343-0228

Email: (Sales)

[FP-Sales-Apps@Honeywell.com](mailto:FP-Sales-Apps@Honeywell.com)

or

(TAC)

[hfs-tac-support@honeywell.com](mailto:hfs-tac-support@honeywell.com)

*Specifications are subject to change without notice*

#### For more information

To learn more about ControlEdge HC900  
Controller, visit [www.honeywellprocess.com](http://www.honeywellprocess.com)  
Or contact your Honeywell Account Manager

#### Process Solutions

Honeywell

1250 W Sam Houston Pkwy S  
Houston, TX 77042

Honeywell Control Systems Ltd  
Honeywell House, Skimped Hill Lane  
Bracknell, England, RG12 1EB

Shanghai City Centre, 100 Jungi Road  
Shanghai, China 20061

[www.honeywellprocess.com](http://www.honeywellprocess.com)



**Honeywell**  
AUTHORIZED DISTRIBUTOR



**Honeywell**  
AUTHORIZED DISTRIBUTOR

**De Gidts & Feldman BV**  
**The Netherlands**  
**www.dgfg.nl**



**De Gidts & Feldman**  
INSTRUMENTATION & FILTRATION

**Honeywell**

51-52-03-43  
September 2018

©2018 Honeywell International Inc.