

Elster® SM-RI-X

Turbine Gas Meter

Sizes from DN200 to 600 (8" to 24")

Applications

Custody Transfer approved Gas Flow Measurement from low to high operating pressures.

Gas Transmission, Distribution and Industrial applications

Brief information

Honeywell Elster SM-RI-X turbine gas meters are robust meters for operation under the most demanding conditions (offshore and onshore). Over decades they have proven to be highly accurate from first calibration on to the end of their lifetime many years later. The longterm measurement stability and highest reliability of the SM-RI have made it become a standard in high volume gas measurement. These are also reasons why SM-RIs are used by recognizable calibration labs around the world as reference meters of choice.

The SM-RI-X is used for custody transfer applications along the complete gas value chain high from production, to pipeline transmission stations, down to local distribution and city gate stations. SM-RI-X turbine meters are also applied at larger industrial and commercial gas consumers where accurate gas measurement is key. Power plants are only one example.

For sizes smaller than DN200 (8") Honeywell offers the TR22 turbine gas meter which is available in sizes DN50 to DN150 (2" to 6").

Operating Principle

The gas flowing through the meter sets the turbine wheel in motion. The number of revolutions of the wheel is proportional to the volume passing through the meter. To optimize measurement performance the patented X4X flow conditioner eliminates flow disturbances such as swirl or asymmetric flow that are created by bends or T-pieces upstream of the meter for example.

After the flow conditioner the cross section of the meter is reduced to increase flow velocity and consequently increase the driving impulse of the medium on the turbine wheel.

The combination of flow conditioning and optimized measurement unit including the turbine wheel make it possible to measure the flow rate accurately even at low flows and pressures. The shaft on which the turbine wheel is fixed is held in place by robust ball bearings that help to maintain high performance for a long time with minimized maintenance needs. Via gears and a magnetic coupling the revolutions of the turbine wheel are transmitted to the 8-digit mechanical counter located in the pressure-less index head.

The outlet of the meter has been optimized to decrease pressure loss and create optimal flow conditions after the meter.



FEATURES & BENEFITS

- MID approval for fiscal measurement
- Conformity to EN12261, PED, ASME, ATEX and IECEx
- Lowest measurement uncertainty
- High repeatability
- Used as reference meter in major calibration facilities
- Meter sizes G650 to G16.000
- Max. measuring range 50 to 25.000 m³/h
- Nominal diameters DN200 to 600 (8" to 24")
- Operating pressure from 0 to 100 barg
- Flange rating in PN 10-100 and ANSI 150-600
- Temperature range: -25 °C to +70 °C
- Compact installation with inlet pipe length L ≥ 2 DN
- Thermowell built into meter housing (optional)
- Integrated HF-pulser (optional)
- Absolute ENCODER (optional)
- Direct mount of Honeywell EVC (optional)
- Designed for natural gas, town gas, butane, air, nitrogen, other gases on request

Multi-Index (MI-2)

The rugged design of the meter index (including the metal cover) has proven itself in the harshest environments and is IP67 certified. The MI-2 is equipped with an 8-digit mechanical index for continuous meter reading.

A low frequency output (reed contact) is included as a standard and can be connected to any Flow Computer or Electronic Volume Corrector.

The pulse output is equipped with inbuilt anti-tampering protection.



Measurement Uncertainty

The SM-RI-X turbine gas meter is designed and manufactured according to the European Standard for turbine meters EN 12261. SM-RI-X fulfills the error limit requirement as follows:

- $\pm 1.0\%$ for $0.2 Q_{max}$ to Q_{max}
- $\pm 2.0\%$ for Q_{min} to $0.2 Q_{max}$
- smaller limits as an option

Pulse outputs

The SM-RI-X can be equipped with low, medium and high frequency outputs depending on customer requirements

Low frequency (standard)

- 1x LF output (type IN-S15) equipped with 1 or 10 magnets depending on resolution requirements

Medium Frequency (optional)

- 1x MF output (type MI-2) built into the meter

High frequency (optional)

- up to 2x HF outputs (one on the turbine wheel and one on the reference wheel) with >500 Hz at Q_{max} (depending on size)

Options available for the MI-2:

- Mechanical instrument Type 25H7 in accordance to EN 12261
- Medium Frequency Output
- Absolute ENCODER for digital data transfer between the meter and Flow Computer / EVC

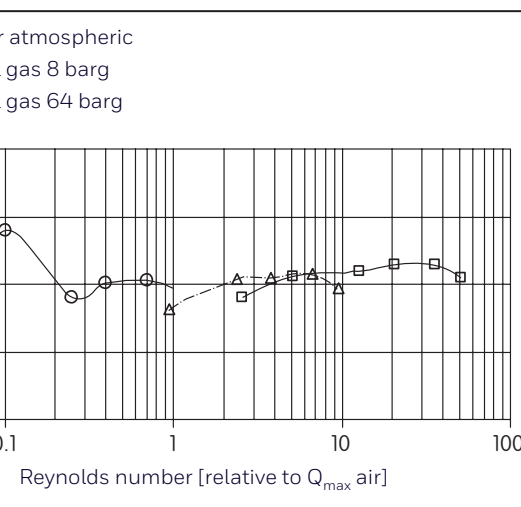

Material

- Meter bodies: ductile iron (GGG-40) or forged steel.
- Turbine wheel: Aluminum

Approvals and Conformity

Elster® SM-RI-X turbine gas meters are manufactured in accordance with DIN EN ISO 9001:2008 (DIN EN ISO 14001).

They are designed, produced and tested in accordance with the following guidelines, standards and references.

General

- European Standard for Turbine Meters EN 12261
- OIML Provision R137-1

Metrology

- EC directive 2014/32/EU (MID)

Hazardous Area

- EC directive 2014/34/EU (ATEX)

Pressure Equipment

- EC directive 2014/68/EU (PED)

Measuring range

Measuring range depending on operating pressure								
			Measuring Range					
			1:20			1:30		1:50
Diameter	Meter Size	Qmax in m³/h	Qmin in m³/h	Minimum Pressure in barg	Qmin in m³/h	Minimum Pressure in barg	Qmin in m³/h	Minimum Pressure in barg
DN 200 8"	G 650	1000	50	0 (atm)	32	12	20	30
	G 1000	1600	80	0 (atm)	50	8	32	20
	G 1600	2500	130	0 (atm)	80	8	50	20
DN 250 10"	G 1000	1600	80	0 (atm)	50	16	32	30
	G 1600	2500	130	0 (atm)	80	4	50	16
	G 2500	4000	200	0 (atm)	130	0 (atm)	80	8
DN 300 12"	G 1600	2500	130	0 (atm)	80	8	50	16
	G 2500	4000	200	0 (atm)	130	4	80	8
	G 4000	6500	320	0 (atm)	200	0 (atm)	130	4
DN 400 16"	G 2500	4000	200	0 (atm)	130	8	80	8
	G 4000	6500	320	0 (atm)	200	4	130	4
	G 6500	10000	500	0 (atm)	320	4	200	8
DN 500 20"	G 4000	6500	320	0 (atm)	200	8	130	16
	G 6500	10000	500	0 (atm)	320	4	200	8
	G 10000	16000	800	0 (atm)	500	4	320	8
DN 600 24"	G 6500	10000	500	0 (atm)	320	8	200	16
	G 10000	16000	800	0 (atm)	500	4	320	8
	G 16000	25000	1250	0 (atm)	800	4	500	8

Pressure loss / Pulse data

Pressure loss				Pulse data		
Diameter	Meter size	Q _{min} - Q _{max} [m³/h]	Pressure loss [mbar] *	LF [1/m³] *	MI-2	HF [Hz at Q _{max}]
DN 200 8"	G 650	50 - 1000	1.5	0.1/1	30	770
	G 1000	80 - 1600	3	0.1/1	47	1180
	G 1600	130 - 2500	8	0.1/1	46	1060
DN 250 10"	G 1000	80 - 1600	1.5	0.1/1	49	825
	G 1600	130 - 2500	4.5	0.1/1	77	1320
	G 2500	200 - 4000	10	0.1/1	69	1200
DN 300 12"	G 1600	130 - 2500	1.5	0.1/1	26	810
	G 2500	200 - 4000	5	0.1/1	42	1270
	G 4000	320 - 6500	14	0.1/1	39	1175
DN 400 16"	G 2500	200 - 4000	1.5	0.1/1	88	660
	G 4000	320 - 6500	5	0.1/1	141	1055
	G 6500	500 - 10000	13	0.1/1	121	890
DN 500 20"	G 4000	320 - 6500	1.5	0.1/1	72	530
	G 6500	500 - 10000	6.5	0.1/1	116	865
	G 10000	800 - 16000	15	0.1/1	105	770
DN 600 24"	G 6500	500 - 10000	1.5	0.01/0.1	26	470
	G 10000	800 - 16000	5	0.01/0.1	41	720
	G 16000	1300 - 25000	10.5	0.01/0.1	38	650



*)Pressure loss calculated at Qmax for natural gas at atmospheric pressure (density 0.8kg/m³) 1D up and downstream of meter specific to single meters and shown on the calibration certificate.

Dimensions and weights												
Diameter	Meter size	Dimensions [mm]					Weight [kg]					
		A	B	C	D	L	PN pressure rates	Housing material	Weight	ANSI pressure rates	Housing material	Weight
DN 200 8"	G 650 G 1000 G 1600	240	240	273	298	600	PN 10	GGG-40 (Steel)	70 (77)	ANSI150	GGG-40 (Steel)	70 (91)
							PN 16	GGG-40 (Steel)	70 (77)	ANSI300	Steel	117
							PN 25	Steel	89	ANSI400	Steel	135
							PN 40	Steel	98	ANSI600	Steel	155
							PN 64	Steel	125			
							PN 100	Steel	161			
DN 250 10"	G 1000 G 1600 G 2500	300	360	327	314	750	PN 10	Steel	90	ANSI150	Steel	108
							PN 16	Steel	95	ANSI300	Steel	148
							PN 25	Steel	108	ANSI400	Steel	170
							PN 40	Steel	128	ANSI600	Steel	236
							PN 64	Steel	156			
							PN 100	Steel	220			
DN 300 12"	G 1600 G 2500 G 4000	360	390	352	338	900	PN 10	Steel	120	ANSI150	Steel	160
							PN 16	Steel	130	ANSI300	Steel	210
							PN 25	Steel	150	ANSI400	Steel	240
							PN 40	Steel	180	ANSI600	Steel	290
							PN 64	Steel	240			
							PN 100	Steel	340			
DN 400 16"	G 2500 G 4000 G 6500	480	510	395	380	1200	PN 10	Steel	350	ANSI150	Steel	400
							PN 16	Steel	380	ANSI300	Steel	460
							PN 25	Steel	410	ANSI400	Steel	490
							PN 40	Steel	460	ANSI600	Steel	580
							PN 64	Steel	510			
DN 500 20"	G 4000 G 6500 G 10000	600	630	445	431	1500	PN 10	Steel	550	ANSI150	Steel	650
							PN 16	Steel	600	ANSI300	Steel	800
							PN 25	Steel	640	ANSI400	Steel	830
							PN 40	Steel	690	ANSI600	Steel	980
DN 600 24"	G 6500 G 10000 G 16000	720	750	495	482	1800	PN 10	Steel	900	ANSI150	Steel	1050
							PN 16	Steel	950	ANSI300	Steel	1300
							PN 25	Steel	1000	ANSI400	Steel	1350
									ANSI600	Steel	1500	

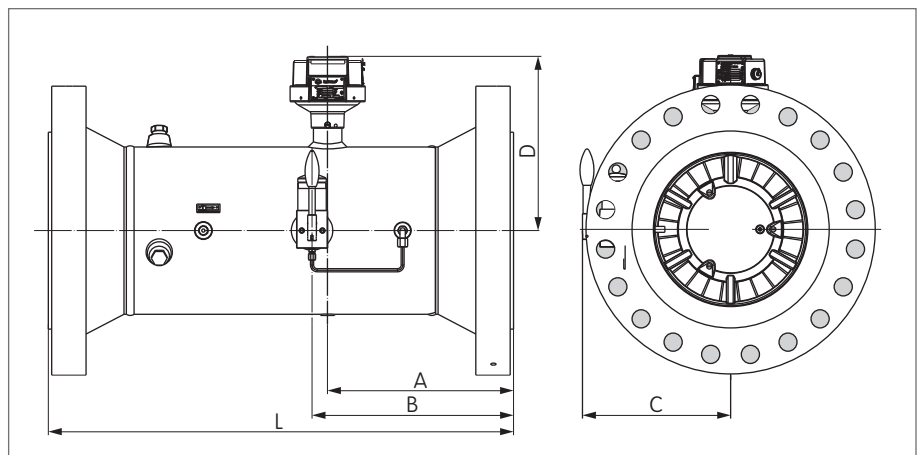

For more information

To learn more about Honeywell Elster's Gas Solutions, visit www.honeywellprocess.com or contact your Honeywell account manager.

Honeywell Process Solutions

Germany
Elster GmbH
Steinern Str. 19-21
55252 Mainz-Kastel
T +49 6134 605 0
F +49 6134 605 223
www.honeywellprocess.com
www.elster-instromet.com

Honeywell
PLATINUM
HPS
DISTRIBUTOR

Honeywell

AUTHORIZED DISTRIBUTOR

De Gidts & Feldman

The Netherlands

www.dgfg.nl

INSTRUMENTATION & FILTRATION

Elster® is a registered trademark of Elster GmbH.
BR-17-05-ENG | 01/17 ©
2017 Honeywell International Inc.

Honeywell