

Gas Odorization System - GOE SO 1-P



PRODUCT INFORMATION

**Serving the Gas Industry
Worldwide**

Honeywell

Gas Odorization System GOE SO1-P

Features, method of operation

Features

- **Odorizes according to the injection method**
Injection is performed by a reciprocating diaphragm pump which is controlled by volume-proportional pulses.
- **Odorant is drawn from the odorant tank by gravity**
No auxiliary pressure is required (neither overpressure nor underpressure). The method is independent of the vapour pressure of the odorant and therefore suitable for all current odorants.
- **High proportioning accuracy**
In this way, a constant odorant concentration is achieved in the gas flow.
- **Wide operating range**
Further extension of the operating range by 1 or 2 additional pumps.
- **High level of reliability**

All parts coming into contact with odorant are manufactured from stainless steel, glass and suitable sealing materials.

- **Infinitely variable setting of the odorant concentration**
The setting of the odorant concentration can be performed at the pump and is also possible during operation.
- **Suitable for use with all common odorants**
e.g. for THT or mercaptans
- **Installed on a mounting plate with SWAGELOK fittings ready for connection**
- **Odorant tank can be filled without interrupting operation**
- **Venting the pump head poses no problems even if the gas line is under pressure**
- **Low on maintenance**
- **Equipped with a stored-program control unit**

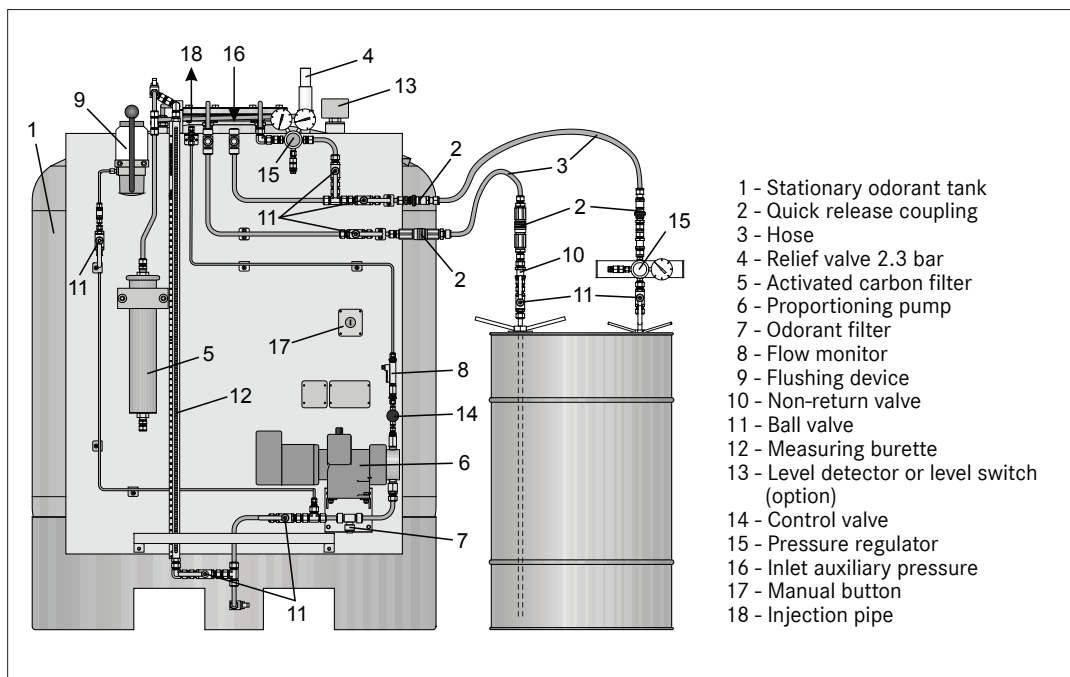

Method of operation

In order to immediately detect natural gas leaking, it is necessary to add an odorous substance (odorant) to the odourless natural gas. Special devices adding the odorant in the required concentration are used for this process, which is called odorization.

The GOE-SO-1P odorization system operates according to the injection method. An electromagnetically operated reciprocating diaphragm pump injects the odorant into the gas flow. The proportioning pump receives an electric pulse from

the associated control unit and then performs a stroke which delivers a settable quantity of odorant. The number and sequence of pulses are determined by the control unit on the basis of volume-proportional pulses received from a volumetric meter. The odorant is drawn directly from a stationary tank from which it flows to the pump by gravity. The additional pressurization with an auxiliary pressure avoids bubble formation in the odorant (e.g. in case of high ambient temperature or with volatile odorants like mercaptans or S-free). Furthermore the auxiliary pressure is used for filling the stationary odorant tank.

Construction

The individual components are fixed to a mounting plate which is directly mounted on the side of the stationary odorant tank.

In the basic version the system contains one pump but it can be equipped with up to 3 pumps which press the odorant into the gas pipe. The odorant flows directly to the pump, caused by gravity. The system operates without vacuum and therefore no problems with the vapour pressure of the odorant appear. By the uncomplex construction with little piping there are few fittings (Swagelok) where leakages can appear.

An activated carbon filter prevents odorant from escaping to the outside when the system is vented. For monitoring purposes, the system can be equipped with a level switch (giving an alarm when the level falls below minimum) or a level detector (level measurement).

Every gas odorization system incorporates a control unit which is normally installed in the safe area. Depending on the desired functional range an elementary device for the basic functions can be used or a device based on a stored-program controller.

consisting of a limit value transmitter and a solenoid valve in the filling pipe.

- **Flow monitor** installed in the injection pipe for monitoring the proportioning pump.
- **Level detector** for continuous level measurement.
- **High-pressure flushing and venting device** for flushing the fittings installed in the suction and injection pipes and for venting the proportioning pump. Maximum gas back pressure: 80 bar.
- **Manual button** (EEx i or EEx d), including manual/automatic changeover, for manual pump control.

Accessories

- **Injection nozzle** for injecting the odorant into the gas flow, including a non-return valve and a manual stop valve. There are different lengths available for nominal pipe diameters from DN 50 to DN 800.
- **Weldolet** (PN 100) for installing the injection nozzle, with G1/2", G3/4" or G1" internal thread.
- **Collector** made of stainless steel, manufactured and tested in compliance with WHG.
- **Insulating coupling** for the injection pipe, dia. 6 mm, for the electrical isolation of the piping and the odorization system.

Options

- **Level switch** giving an alarm when the filling level falls below a present minimum value.
- **Overflow controller**, built in the odorant tank,

Specifications						
Dimensions/ Weights						
tank size (liters)	200	400	600	800	1000	1200
height (mm)	1400	1400	1400	1400	1490	1670
width (mm)	1000	1000	1000	1000	1100	1200
depth (mm)	900	1100	1200	1300	1400	1500
weight (mm)	140	180	205	245	275	300
connection of injection pipe	Ø 6 mm SWAGELOK fitting					
power supply	230 V/AC (via control unit)					
power requirement	approx. 56 VA					
ambient temperature range	+5 to +50 °C					
explosion protection	II 2G EEx e G 4, approved for Zone 1					
immersion length of injector nozzle	DN 50 - DN 100:	93 mm		DN 150:	143 mm	
	DN 200:	178 mm		DN 250 - DN 300:	190 mm	
	DN 400 - DN 500:	320 mm		DN 600 - DN 800:	480 mm	

For More Information

To learn more about Honeywell's
Advanced Gas Solutions, visit
www.honeywellprocess.com or contact
your Honeywell account manager

GERMANY**Honeywell Process Solutions**

Honeywell Gas Technologies GmbH
Osterholzstrasse 45
34123 Kassel, Deutschland
Tel: +49 (0)561 5007-0
Fax: +49 (0)561 5007-107

Gas Odorization System GOE SO 1-P
2017-02
© 2017 Honeywell International Inc.

Honeywell